

LR376 - ADJUSTABLE BAFFLE 6" LINE VOLTAGE TRIMS

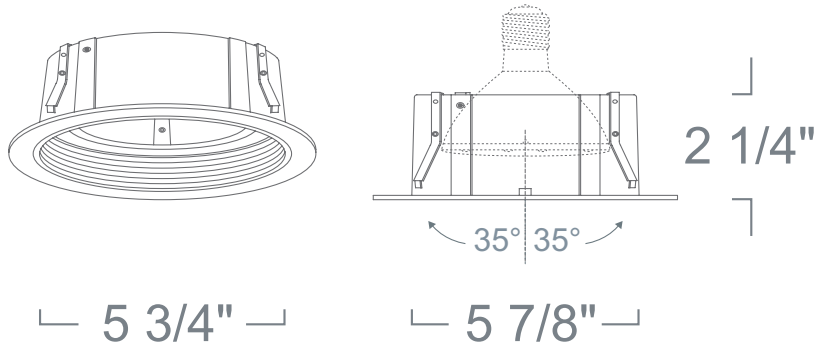

SPECIFICATION

120V 75W Max PAR30 MED E26





Application: Standard in residential adjustable illumination, the **gimbal** style trims provides flexibility and versatility from a single rotary axis. They double as both a downlight and as an accent light. They are an economical way to provide general and accent lighting with both vertical and horizontal aiming capabilities. Their large degrees of rotation result in both streamlined style and practical ergonomics. **PAR30** gimbals offer a smaller opening aperture, as well as a more controlled light beam for accenting objects. **Regressed** gimbal design conveniently helps shield lamp glare from surrounding environment.

Mounting: Steel pressure springs mounted on trim to ensure positive retention inside housing.

Baffle Finish: Die-formed aluminum baffle ridges eliminate stray light. Available in White, Black and All Natural*.

Ring Finish: Die-Formed Aluminum Trim Ring Available in White, Black, Chrome, Gold, Natural, Copper and Mocha.

COMPATIBILITY

 LH27 STANDARD SHALLOW E26 HOUSING	 LH27R REMODEL SHALLOW E2 HOUSING	 LH7 STANDARD E26 HOUSING
 LH7IC 100W IC E26 HOUSING	 LH7R REMODEL E26 HOUSING	

Note: Wattage limitations on compatible items must be met.

2016.7.27

FEATURE:



ORDERING EXAMPLE : LR376NB

LR376	BAFFLE FINISH	RING FINISH
LR376	W :White	Blank :White
	B :Black	B :Black
	N :All Natural*	C :Chrome
		G :Gold
		N :Natural
		CO :Copper
		MO :Mocha

* Comes standard with a matching ring finish. Use "W" for White Ring.

ID#: 14