

## LVH8 - 8" LIGHT COMMERCIAL HOUSING

### LVH8 SERIES - 8" LIGHT COMMERCIAL CFL HOUSINGS

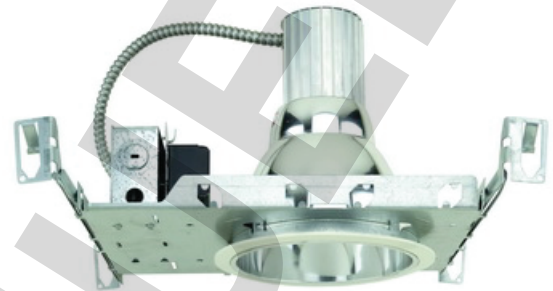
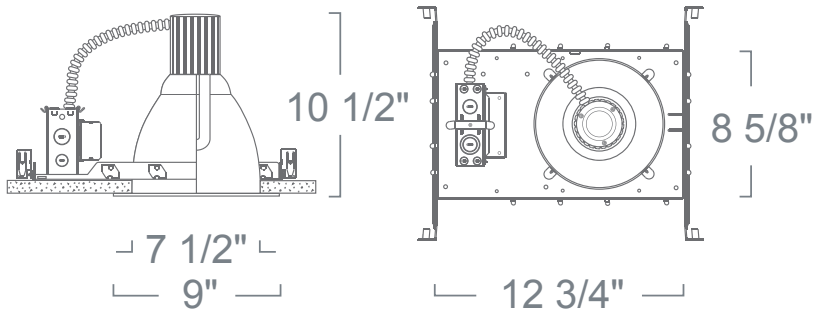

### SPECIFICATION

CFL 70W Max

**Application:** Light commercial recessed downlight housing for medium to high ceilings for commercial and high-end residential installations. A variety of compatible trim styles and finishes are available to achieve the proper illumination.

**Housing & Mounting Frame:** 18 gauge galvanized flat frame with powder coat finish for ceiling up to 2 1/4" thick. Supplied with (2) 24" adjustable bar hangers (90 degrees repositioning ability). Bar hangers equipped with (nail-less installation) 3/4" serrated barbed studs for secure mounting in wood joists. Can also be mounted to grid panel ceiling. Earthquake structural cable compatible for drop panel ceiling or any other mounting that requires direct support from structural ceilings.

**Ballast:** Electronic Class P 60Hz Ballast with Inherent thermal protection. For Double Twin Tube (DTT) or Triple Twin Tube Lamps (TTT). Sound A rated. Micro-Processor controlled. Min. starting temperature -10°C. Accessible from above or below the ceiling. Contact factory for detailed technical information on ballast specifications. Note: For dimming applications must use compatible dimmer switch. Consult specific ballast manufacturer for up-to-date compatibility list.

**Socket Cap:** Extruded aluminum socket cap, 1 1/4" vertically adjustable socket arm with set screw which enables the use of multiple lamp types and repositioning to optimize lamp performance. Furnished with heat sink fins to vent lamp heat and extend lamp life. Accepts compatible reflector trims.

**Socket:** Thermo-plastic socket UL Listed rated for high temperature and provides nickel plated contacts. Either accepts 2-Pin lamps for use with magnetic ballast or 4-Pin lamps with electronic ballast selection. Vertically adjustable galvanized steel plate enables lamp repositioning to optimize performance.

**Junction Box:** 16 gauge pre-wired galvanized steel Junction Box, 32 cubic-inch for a maximum of (8) #12 AWG wires. Furnished with (6) 3/4" and (4) Romex knock-outs. Strain clamps to install or remove covers for easy access and ground wire. Equipped with safety standard fitting for flex-conduit.

**Insulation Contact:** Non-IC rated housing must be kept 3" from insulation.

**Safety Labels:** UL/CUL listed for through-branch wiring (8) No.12 AWG 90°C and suitable for damp locations. NYC approved: Calendar #41937.

**Emergency Option:** Emergency back-up operates one lamp for a minimum of 90 minutes at 750 Lumens in case of power outage. Unit is remotely mounted. It includes battery, charger, and test switch with indicator light. Consult Factory for 1300 Lumen Package.

**Label:** UL Listed, cETL Listed

Assembled in USA

### FEATURE:



LVH8	WATTAGE	BALLAST	OPTION
LVH8	13 :13W	UD :0-10V Dimming (120V/277V)	Blank :None
	18 :18W	E :Electronic (120V)	-EM :Emergency
	26 :26W	E-27 :Electronic (120V/277V)	-FS :Fuse
	32 :32W		
	42 :42W		
	57 :57W		
	70 :70W		

### COMPATIBILITY

 LFB2012 FIRE BARRIER	 LR801 REFLECTOR	 LR806 CROSS BLADE REFLECTOR
 CRTR8L 8" COMMERCIAL LED RETROFIT	 CRTR8L 8" COMMERCIAL LED RETROFIT AMBER	

Note: Wattage limitations on compatible items must be met.

2016.6.14

ORDERING EXAMPLE : LVH818E

ID#: 1501