

SL732 - 11" STEP LIGHT WITH ANGLED LOUVER FACEPLATE

LED PATHWAY/STEP LIGHTING

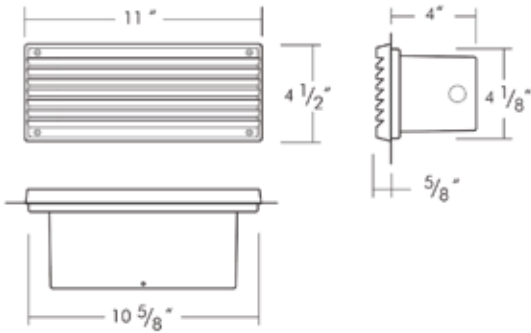

SPECIFICATION

11W/20W

Applications: Recessed wall luminaire designed for commercial, architectural, and residential installation. Designed to conform to the architectural requirements for low mounting heights for the illumination of steps, stairways, walkways, aisles, ramps and other indoor and outdoor applications. Can be mounted vertically.

Housing: High grade die cast aluminum with an integral wiring compartment, silicone gasket. Two (2) 1/2-14 NPSM conduit provided.

Faceplate: Rectangular angled louver one-piece high grade die cast aluminum faceplate with a high corrosion-resistant powder coat finish and semi-translucent polycarbonate lens. Faceplate is installed by four (4), captive, tamper resistant, stainless steel screws.

Electrical: 120V/277V Modular LED Engine (Field Replaceable) Consult Factory for dimming and sensor options.

Listing: UL / cUL / ETL / cETL Listed, suitable for wet location and for all types of constructions including use in poured concrete, Type IC (CF lamps), Type Non-IC (CF, T10 40W max. lamps), ADA compliant and suitable for installation within 4 feet of the ground. Assembled in USA. (IP65).

Warranty: Covered by a 5 Year Warranty to be free of defects in materials and craftsmanship.

Finish: Available in Black, Bronze*, Silver* and White.

Lumens: Available in 11W/1000lm and 20W/1500lm.

Color Temp: Available in 3000K, 3500K**, 4000K, 5000K** and Color Changing (Consult Factory).

LED Details:

1000 Lumens delivered
Color Rendering Index (CRI): 80
Lamp Equivalents: 100W A19 32W CFL

Benefit:

- High Quality Die-Cast Construction
- High 80CRI
- 120V/277V Option
- 5 Year Warranty
- 32W CFL Equivalent

2019.09.18



ORDERING EXAMPLE : SL732B-RGBW

SL732	FINISH	LUMENS	OPTIONS	COLOR TEMP
SL732	B :Black	Blank :11W/1000lm	Blank :120V	-T30 :3000K
	BZ :Bronze*	-L15 :20W/1500lm	UE :120V/277V	-T35 :3500K**
	S :Silver*		UE-DUN :120V/277V 2-Wire, ELV &	-T40 :4000K
	W :White		0-10V Dimming	-T50 :5000K**
				-RGBW :Color Changing (Consult Factory)

* Extended Lead Time may apply. ** Special Order. Minimum amount required and extended lead times may apply.