

Please consult a qualified electrician for hanging fixture and wiring.

CAUTION: Before starting the installation, disconnect the power by turning off the circuit breaker or by removing the fuse at the fuse box. Carefully unpack and identify all parts before assembly

Step 1

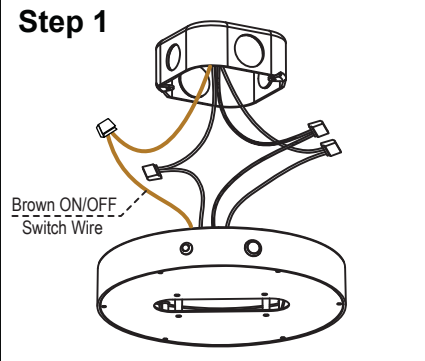

Brown ON/OFF Switch Wire

Connect the three cables available for connection into junction box. For Emergency back up unit, black wire is positive, white wire is negative, yellow wire is ground wire.

Step 2

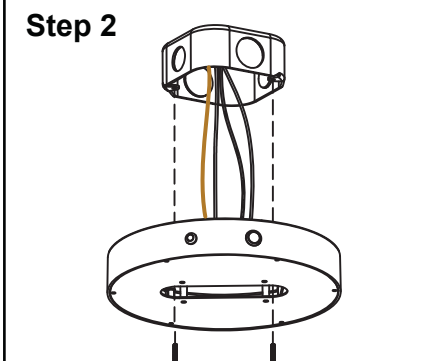

Screw the Emergency back up unit up into the junction box using the 2*M4 screw provided,

Step 3

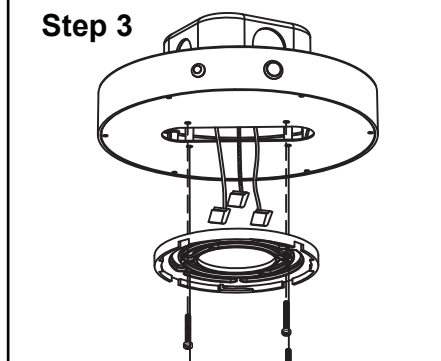

Screw the mounting plate to the Emergency back up unit

Step 4

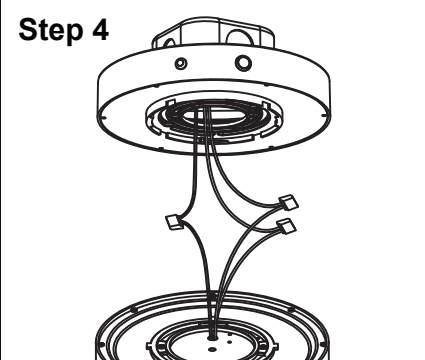

Connect the fixture wire available for connection into the Emergency back up unit.

Step 5

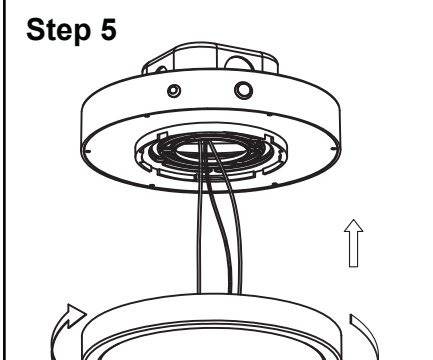

Install the fixture to the Emergency back up unit.

Step 6

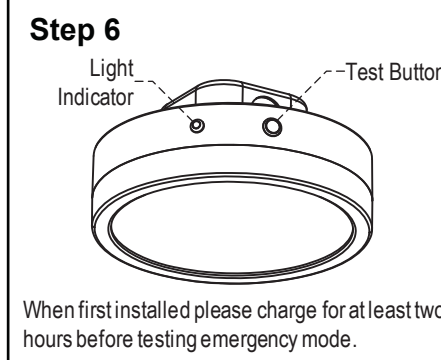

Light Indicator Test Button

When first installed please charge for at least two hours before testing emergency mode.

Press Button to enter EM mode, shown by the light indicator being off.

Press button to go back to AC mode, indicated by steady/flashing(charging) light.