

## LHALD8R25 - 8" ARCHITECTURAL REMODEL LED FRAME-KIT (1400/1900/2000/3000 LUMEN) 8" LED ARCHITECTURAL DOWNLIGHT

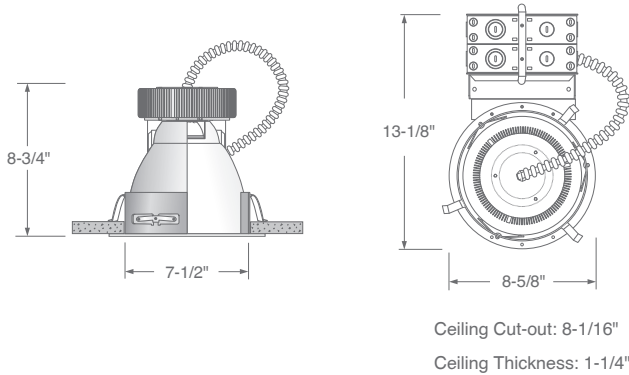

### SPECIFICATION

19W/25W/28W LED

**Application:** Architectural-grade recessed LED downlight housing for medium to high ceilings in commercial and architectural spaces.

**Housing Frame:** 16 gauge galvanized plaster ring with black powder coat finish, friction or V-Spring clips secure trim to housing.

**Mounting:** Housing suitable for new construction installations only, Bat-Wing bar hanger brackets adjust vertically 3 1/4" for multiple ceiling types and accepts 1/2" EMT, 26" C-Channel Strut for T-bar ceilings and 27" adjustable linear hanger bars for plaster ceilings or wood/metal joists. Heavy duty 16-gauge, die-formed galvanized steel. Bar hangers optional.

**Mounting:** Housing suitable for existing or new construction installations, supplied with 4 high tension remodeling clips, designed to secure the housing to an existing sheetrock ceiling up to 1" thick for fast and easy installation from below the ceiling line.

**Driver:** 120V/277V AC 50/60Hz Electronic Direct Current Class 2 driver integrally mounted on large access Junction Box. Power Factor > 0.90. Operating Temperature: -10°C to +80°C. Accessible from above or below ceiling. Consult Factory for dimming options and compatible dimmers.

**Emergency Options:** Emergency LED Battery Back-up available, remotely mounted adjacent to housing by installer. When AC power fails, the device immediately switches to the emergency mode, operating the LEDs for a minimum of 90 minutes. Remote test switch and plate cover included. Optional Generator Transfer Device switches the driver to auxiliary generator power during the loss of normal AC power, (recommended for applications requiring individual circuit switching).

**Junction Box:** 16 gauge pre-wired galvanized steel double Junction Box, 64 cubic-inch for a maximum of (8) #12 AWG wires. Furnished with (10) 3/4", (2) 1" and (8) Romex knock-outs. Strain clamps to install or remove covers for easy access and ground wire. Equipped with safety standard die-cast aluminum fitting for flex-conduit.

**Insulation Contact:** Non-IC rated housing must be kept 3" from insulation.

**Dimming:** 0-10V dimming option (-D10) works with most 5-Wire 0-10V dimmers. Available with 1% Deep Dimming Option. Factory qualified for use with Leviton IP710-DLX and Lutron NTFTV-WH. The Lutron Hi-Lume (-DHL) and Ecosystem (-DEC) option designed for use with LUTRON Ecosystem Controls. Uni-Dim™ (-DUN) option is a universal dimming system that works with most 3-Wire ELV, 2-Wire Incandescent and 5-Wire 0-10V fluorescent dimmers.

**Warranty:** Covered by a 5 Year Warranty to be free of defects in materials and craftsmanship. Recommended for applications where ambient temperatures do not exceed 35°C, installations exceeding this temperature will result in reduced LED lamp life and a voided warranty.

### COMPATIBILITY



**LRALD8**

**8" ARCHITECTURAL  
LED TRIM  
(1400/2000/3000)**



**LRCLD802**

**8" ARCHITECTURAL  
SHALLOW LED  
RETROFIT (1200/1900)**

Note: Wattage limitations on compatible items must be met.

**Caution:** LITON recommends use of surge protectors on the power entering LED Housings. Surge damage is not covered by warranty.

**DRIVER TYPE:** Available in 0-10V 1% Dimming, 0-10V 10% Dimming, 2-Wire 0% Dimming (120V), Hilume 1% Dimming, Lutron Ecosystem, Non-Dimming and UniDim™ Universal Dimming.

**OPTION:** Available in Emergency (10W).

**Label:** cETL Listed

**Assembled in USA**

#### Benefit:

- Frame-in Kit works with both 1400, 1900, 2000, & 3000 lumen packages
- 25W Housing/Trim combos are Energy Star Qualified
- Heavy-duty aluminum LED connector assures firm connection.
- Exclusive UniDim™ Universal LED Dimming Option works with 0-10V, ELV and Incandescent Control Systems
- Fast lead times!

2019.08.21

### FEATURE:



ORDERING EXAMPLE : LHALD8R25C070UE

LHALD8R25	DRIVER TYPE	OPTION
<b>LHALD8R25</b>	<b>C070-DINPZ</b> :2-Wire 0% Dimming (120V)	<b>Blank</b> :None
<b>C070UE</b>	:Non-Dimming	<b>-EM2</b> :Emergency (10W)
<b>C070UE-D10</b>	:0-10V 10% Dimming	
<b>C070UE-D10P1</b>	:0-10V 1% Dimming	
<b>C070UE-DEC</b>	:Lutron Ecosystem	
<b>C070UE-DHL</b>	:Hilume 1% Dimming	
<b>C070UE-DUN</b>	:UniDim™ Universal Dimming	

ID#: 2958