



SCC11

Touch Panel (RGBW)



Manual

www.rgbw.com

Technical Specs

SCC11 RGBW Touch Panel

Input Voltage:	5Vdc, 0.5A~1A (with a power adapter)
Output Signal:	RF 2.4GHz, DMX512
Control Mode:	RGBW, 4 Zones Control
Working Temp.:	-30°C ~ 55°C
Package Size:	L132xW192xH50(mm)
Weight(N.W.):	230g
Weight(G.W.):	370g

Product Size

Unit: inch

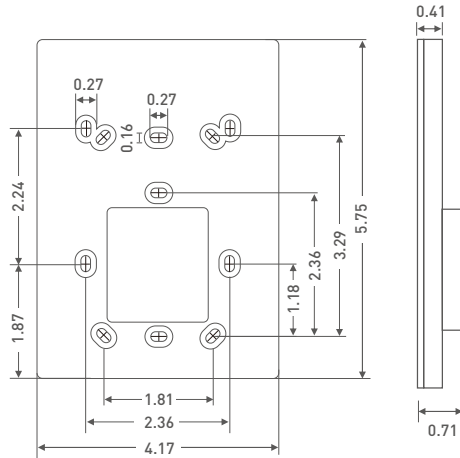

Key Functions

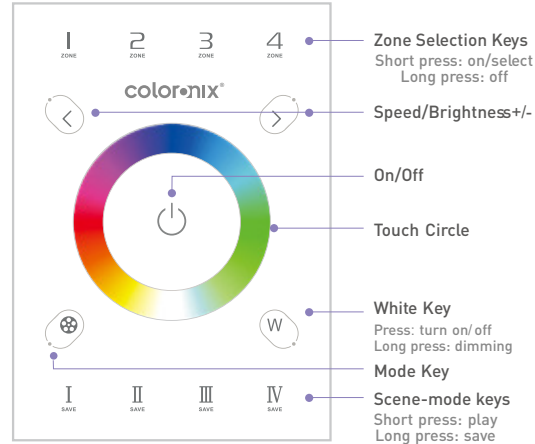

The Changing Mode (Press ⚙ to Select):

1. Static Red
2. Static Green
3. Static Blue
4. Static Yellow
5. Static Purple
6. Static Cyan
7. Static White
8. RGB Jumping
9. 7 Colors Jumping
10. RGB Smooth
11. 7 Colors Smooth
12. Static Black

Terminals

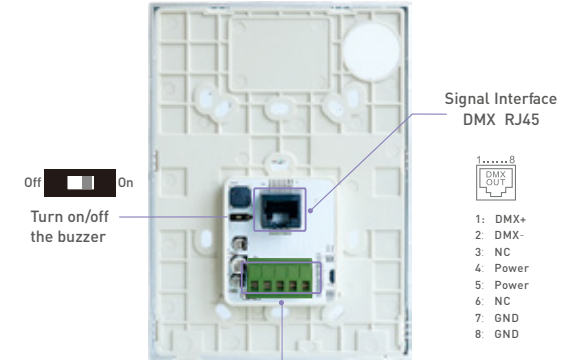

Off On
Turn on/off the buzzer

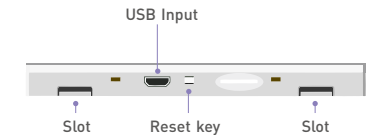
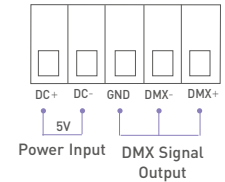

Installation Instruction

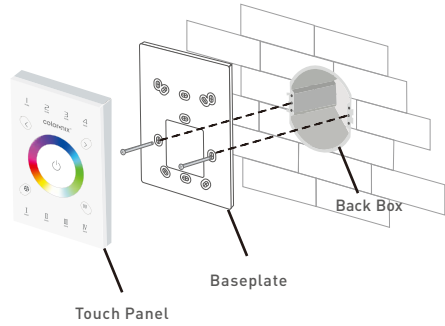

1. Install the back box into the wall. Typical boxes as below:

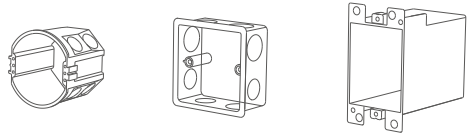

2 Use a straight screwdriver to pry the position shown:

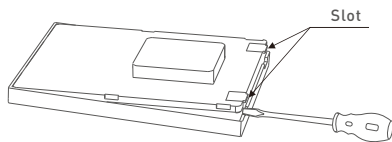

3. screw the baseplate and the back box in the wall firmly.

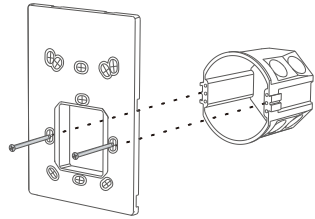

4 Connect in a right way and put the power adapter into the back box.

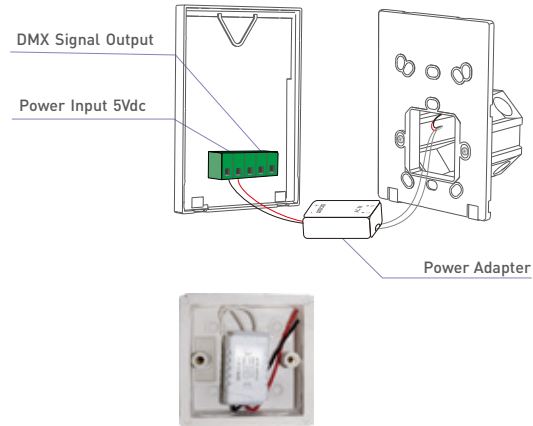

5 Embed the upper touch panel into the baseplate and then tap the bottom to press into the slots.

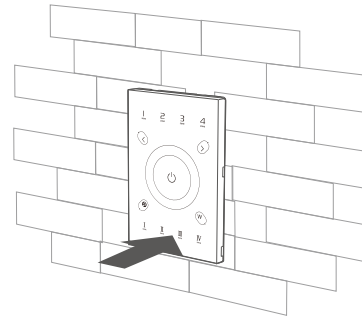
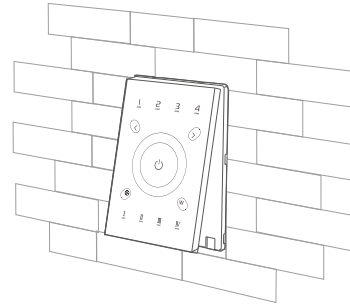

DMX Output Wiring

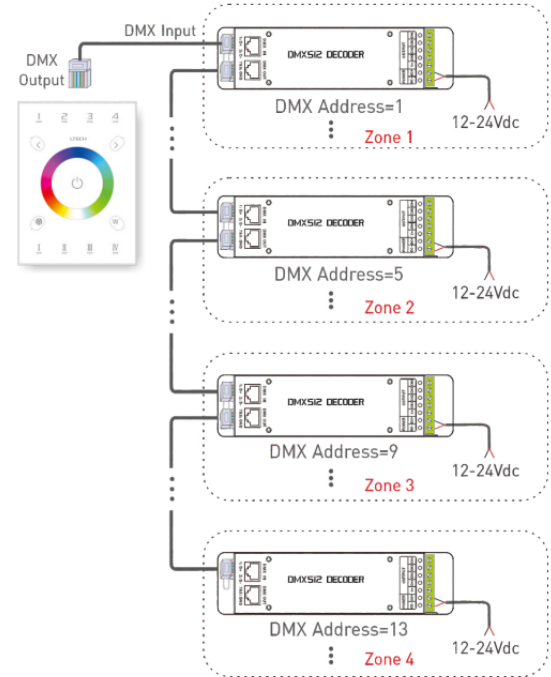

Warranty Agreement

1. We provide lifelong technical assistance with this product:

- A 5-year warranty is given from the date of purchase. The warranty is for free repair or replacement if cover manufacturing faults only.
- For faults beyond the 5-year warranty, we reserve the right to charge for time and parts.

2. Warranty exclusions below:

- Any man-made damages caused from improper operation, or connecting to excess voltage and overloading.
- The product appears to have excessive physical damage.
- Damage due to natural disasters and force majeure.
- Warranty label, fragile label and unique barcode label have been damaged.
- The product has been replaced by a brand new product.

3. Repair or replacement as provided under this warranty is the exclusive remedy to the customer. We shall not be liable for any incidental or consequential damages for breach of any stipulation in this warranty.

4. Any amendment or adjustment to this warranty must be approved in writing by our company only.

※ No further notice if any changes in the manual.

Product function depends on the goods.

Please feel free to contact our official distributor if any question.